

APPLICATION NOTE 1890

An Introduction to Direct-Sequence Spread-Spectrum Communications

A tutorial overview of spread spectrum principles. Covers both direct sequence and fast hopping methods. Theoretical equations are given to allow performance estimates. Relation to CDMA and TDMA is provided. Schematic of a code sequence generator is shown. Spectral plots are shown for DSSS and FHSS methods.

Introduction

As spread spectrum techniques become increasingly popular, electrical engineers outside the field are eager for understandable explanations of the technology. There are many books and web sites on the subject but many are hard to understand or describe some aspects while ignoring others (the DSSS type, for instance, with extensive focus on PN-code generation).

The following discussion covers the full spectrum (pun intended).

A Short History

Spread-spectrum (SS) communications technology was first described on paper by an actress and a musician! In 1941, Hollywood actress Hedy Lamarr and pianist George Antheil described a secure radio link to control torpedos and received U.S. patent #2.292.387. It was not taken seriously at that time by the U.S. Army and was forgotten until the 1980s, when it came alive, and has become increasingly popular for applications that involve radio links in hostile environments.

Typical applications for the resulting short-range data transceivers include satellite-positioning systems (GPS), 3G mobile telecommunications, W-LAN (IEEE802.11a, IEEE802.11b, IEEE802.11g), and Bluetooth. SS techniques also aid in the endless race between communication needs and radio-frequency availability (the radio spectrum is limited, and is therefore an expensive resource).

Theoretical Justification for SS

SS is apparent in the Shannon and Hartley channel-capacity theorem:

$$C = B \cdot \log_2 (1 + S/N)$$

In this equation, C is the channel capacity in bits per second (bps), which is the maximum data rate for a theoretical bit-error rate (BER). B is the required channel bandwidth in Hz, and S/N is the signal-to-noise power ratio. To be more explicit, one assumes that C , which represents the amount of information allowed by the communication channel, also represents the desired performance. Bandwidth (B) is the price to be paid, because frequency is a limited resource. S/N ratio expresses the environmental conditions or the physical characteristics (obstacles, presence of jammers, interferences, etc.).

An elegant interpretation of this equation, applicable for difficult environments (low S/N ratio caused by noise and interference), says that one can maintain or even increase communication performance (high C) by allowing or injecting more bandwidth (high B), even when signal power is below the noise floor. (The equation does not forbid that condition!)

Modify the above equation by changing the log base from 2 to e (the Napierian number), and by noting that $\text{Ln} = \text{Log}_e$:

$$C/B = (1/\text{Ln}2) \cdot \text{Ln}(1+S/N) = 1.443 \cdot \text{Ln}(1+S/N)$$

Applying the MacLaurin series development for $\text{Ln}(1+x) = x - x^2/2 + x^3/3 - x^4/4 + \dots + (-1)^{k+1}x^k/k + \dots$:

$$C/B = 1.443 \cdot (S/N - 1/2 \cdot (S/N)^2 + 1/3 \cdot (S/N)^3 - \dots)$$

S/N is usually low for spread-spectrum applications. (As just mentioned, the signal power density can be even below the noise level.) Assuming a noise level such that $S/N \ll 1$, Shannon's expression becomes simply:

$$C/B \approx 1.433 \cdot S/N$$

Very roughly,

$$C/B \approx S/N$$

$$\text{Or : } N/S \approx B/C$$

To send error-free information for a given noise-to-signal ratio in the channel, therefore, we need only perform the fundamental SS signal-spreading operation: increase the transmitted bandwidth. That principle seems simple and evident, but its implementation is complexæmainly because spreading the baseband (by a factor that can be several orders of magnitude) forces the electronics to act and react accordingly, making necessary the spreading and despreading operations.

Definitions

Different SS techniques are available, but all have one idea in common: the key (also called code or sequence) attached to the communication channel. The manner of inserting this code defines precisely the SS technique in question. The term "spread spectrum" refers to the expansion of signal bandwidth, by several orders of magnitude in some cases, which occurs when a key is attached to the communication channel.

The formal definition of SS is more precise: Spread spectrum is an RF communications system in which the baseband signal bandwidth is intentionally spread over a larger bandwidth by injecting a higher-frequency signal. As a direct consequence, energy used in transmitting the signal is spread over a wider bandwidth, and appears as noise. The ratio (in dB) between the spread baseband and the original signal is called processing gain. Typical SS processing gains run from 10dB to 60dB.

To apply an SS technique, simply inject the corresponding SS code somewhere in the transmitting chain before the antenna. (That injection is called the spreading operation.) The effect is to diffuse the information in a larger bandwidth. Conversely, you can remove the SS code (despreading operation) at a point in the receive chain before data retrieval. The effect of a despreading operation is to reconstitute the information in its original bandwidth. Obviously, the same code must be known in advance at both ends of the transmission channel. (In some circumstances, it should be known only by those two parties.)

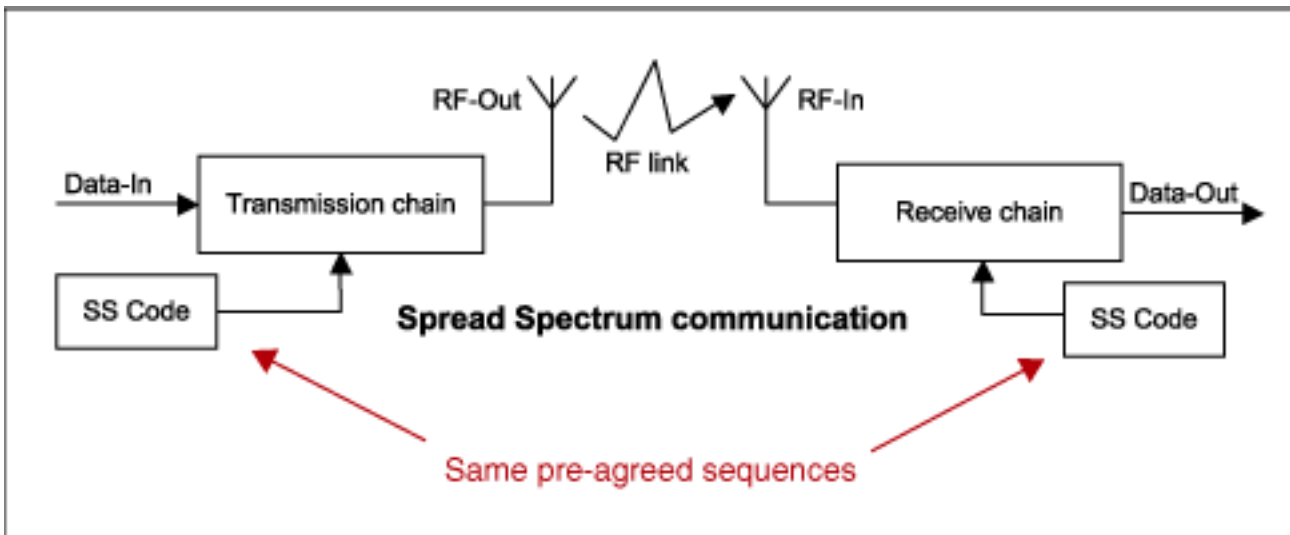

Figure 1.

Bandwidth Effects of the Spreading Operation

The simple drawings below illustrate the evaluation of signal bandwidths in a communication link.

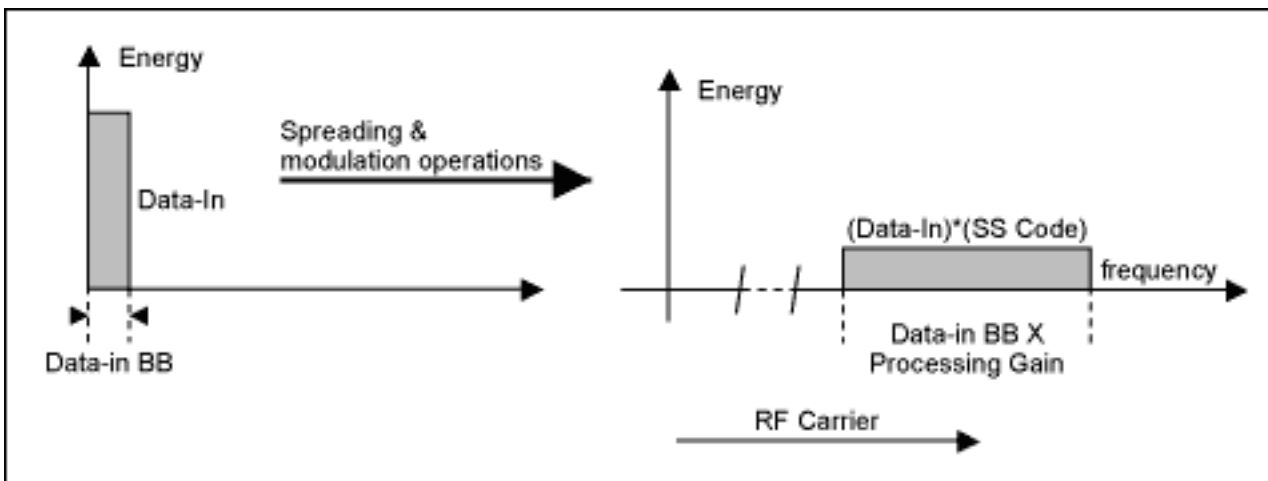

Figure 2.

SS modulation is applied on top of a conventional modulation such as BPSK or direct conversion. One can demonstrate that all other signals not receiving the SS code will stay as they are, unspread.

Bandwidth Effects of the Despreading Operation

Similarly, despreading can be seen as follows:

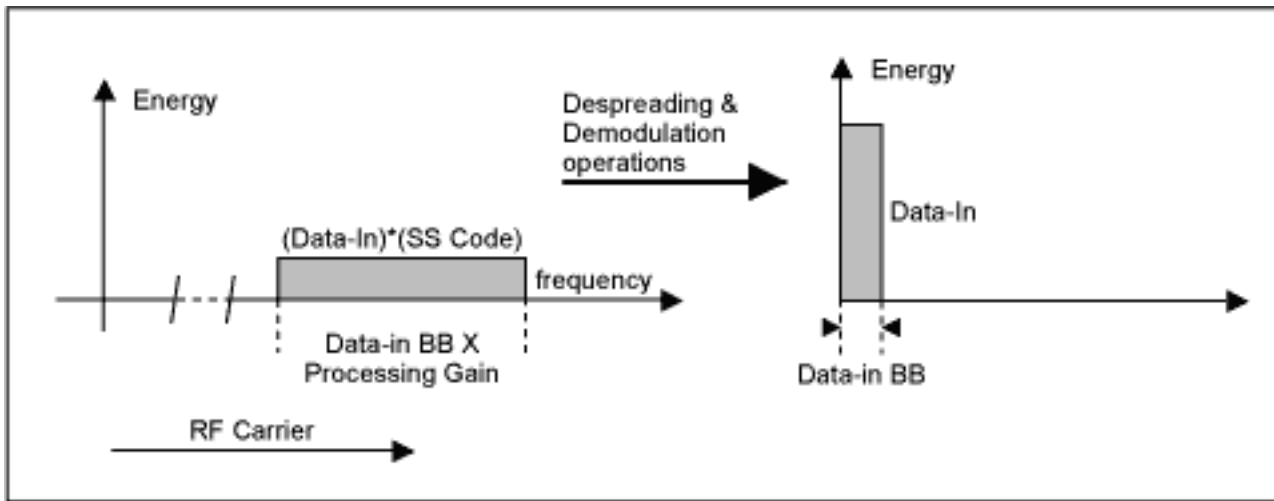

Figure 3.

An SS demodulation has been made on top of the normal demodulation operations above. One can also demonstrate that signals added during the transmission (such as an interferer or jammer) will be spread during the despreading operation!

Waste of Bandwidth Due to Spreading is Offset by Multiple Users

Spreading results directly in the use of a wider frequency band (by a factor corresponding exactly to the "processing gain" mentioned earlier), so it doesn't spare the limited frequency resource. That overuse is well compensated, however, by the possibility that many users will share the enlarged frequency band.

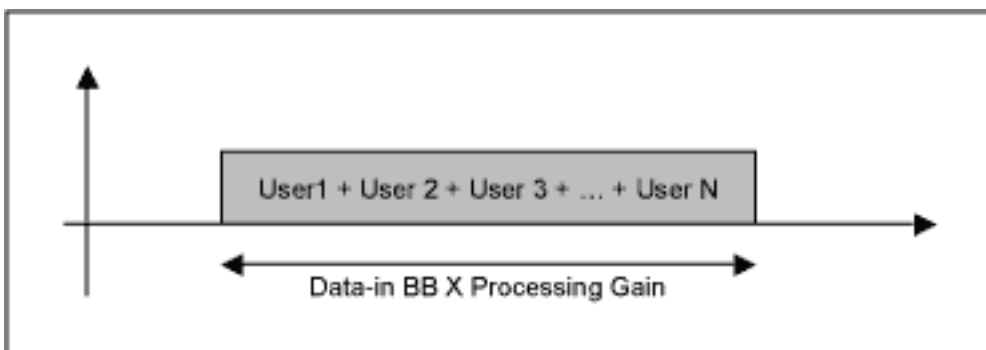

Figure 4.

SS is Wideband Technology

As opposed to regular narrowband technology, the SS process of spreading is a wideband technology. W-CDMA and UMTS, for example, are wideband technologies that require a relatively large frequency bandwidth (compared to that of narrowband radio).

Resistance to Interference, and Anti-jamming Effects

This characteristic is the real beauty of SS. Intentional or un-intentional interference and jamming signals are rejected because they do not contain the SS key. Only the desired signal, which has the key, will be seen at the receiver when the despreading operation is exercised.

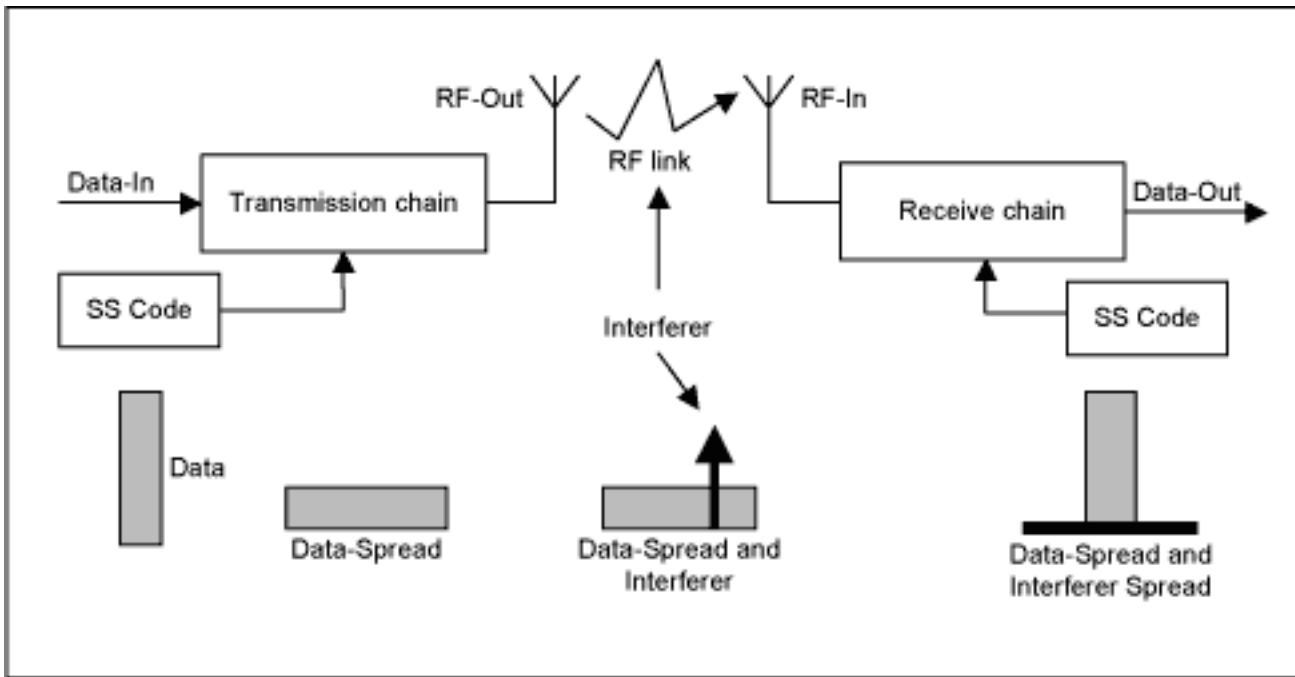

Figure 5.

You can practically ignore the interference (narrowband or wideband) if it does not include the key used in the despreading operation. That rejection also applies to other SS signals not having the right key, which allows different SS communications to be active simultaneously in the same band (such as CDMA). Note that SS is a wideband technology, but the reverse is not true. Wideband techniques need not involve SS technology.

Resistance to Interception

Resistance to interception is the second advantage provided by SS techniques. Because non-authorized listeners do not have the key used to spread the original signal, they cannot decode it. Without the right key, the SS signal appears as noise or as an interferer (scanning methods can break the code, however, if the key is short.) Even better, signal levels can be below the noise floor, because the spreading operation reduces the spectral density (total energy is the same, but it is widely spread in frequency). The message is thus made invisible, an effect that is particularly strong with the DSSS technique. Other receivers cannot "see" the transmission; they only register a slight increase in the overall noise level!

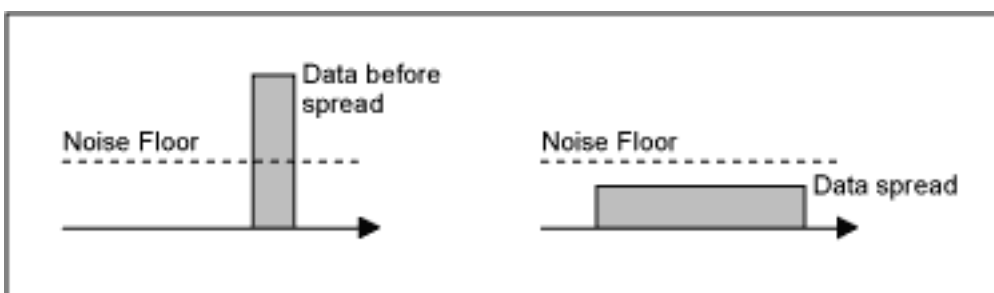

Figure 6.

Resistance to Fading (Multipath Effects)

Wireless channels often include multiple-path propagation, in which the signal has more than one path from the transmitter to the receiver. Such multipaths can be caused by atmospheric reflection or refraction, and by reflection from the ground or from objects such as buildings.

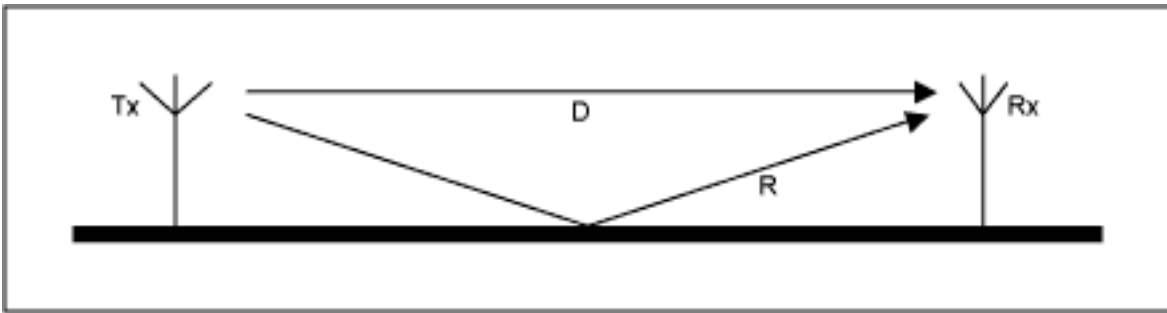

Figure 7.

The reflected path (R) can interfere with the direct path (D) in a phenomenon called fading. Because the despreading process synchronizes to signal D, signal R is rejected even though it contains the same key. Methods are available to use the reflected-path signals by despreading them and adding the extracted results to the main one.

SS Allows CDMA

Note that SS is not a modulation scheme, and should not be confused with other types of modulation. One can, for example, use SS techniques to transmit a signal modulated via FSK or BPSK. Thanks to the coding basis, SS can also be used as another method for implementing multiple access (the real or apparent coexistence of multiple and simultaneous communication links on the same physical media). So far, three main methods are available:

FDMA: Frequency Division Multiple Access. FDMA allocates a specific carrier frequency to a communication channel, and the number of different users is limited to the number of slices in the frequency spectrum. FDMA is the least efficient in term of frequency-band usage. Methods of FDMA access include radio broadcasting, TV, AMPS, and TETRAPOLE.

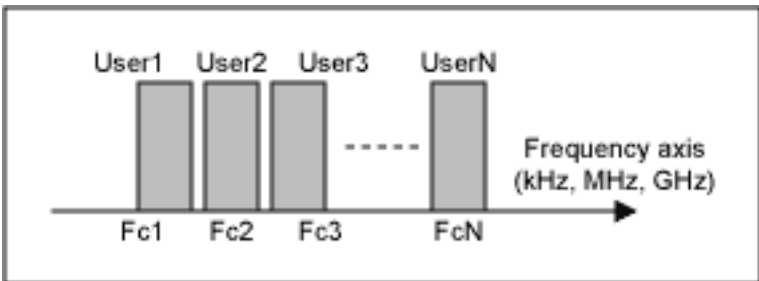

Figure 8.

TDMA: Time Division Multiple Access. Here, the different users speak and listen to each other according to a defined allocation of time slots. Different communication channels can then be established for a unique carrier frequency. Examples of TDMA are GSM, DECT, TETRA, and IS-136.

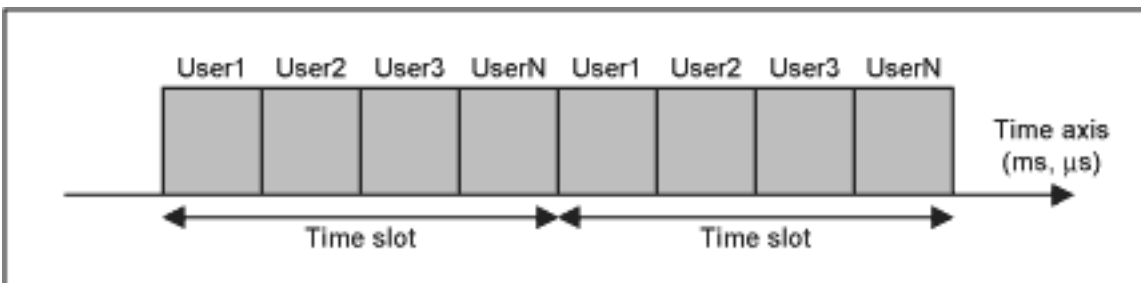

Figure 9.

CDMA: Code Division Multiple Access. CDMA access to the air is determined by a key or code. In that sense, spread spectrum is a CDMA access. The key must be defined and known in advance at the transmitter and receiver ends. Growing examples are IS-95 (DS), IS-98, Bluetooth, and WLAN.

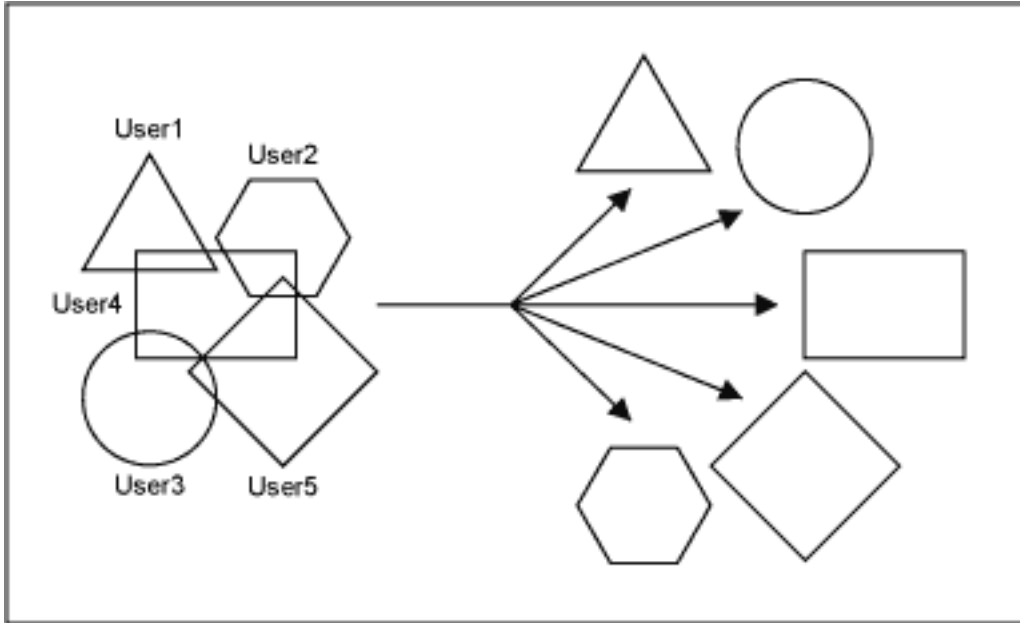

Figure 10.

One can, of course, combine the above access methods. GSM, for instance, combines TDMA and FDMA. It defines the topological areas (cells) with different carrier frequencies, and sets time slots within each cell.

Spread Spectrum and (De)coding "Keys"

At this point, we know that the main SS characteristic is the presence of a code or key, which must be known in advance by the transmitter and receiver(s). In modern communications, the codes are digital sequences that must be as long and as random as possible to appear as "noise-like" as possible. But in any case, they must remain reproducible. Otherwise, the receiver will be unable to extract the message that has been sent. Thus, the sequence is "nearly random." Such a code is called a pseudo-random number (PRN) or sequence. The method most frequently used to generate pseudo-random codes is based on a feedback shift register:

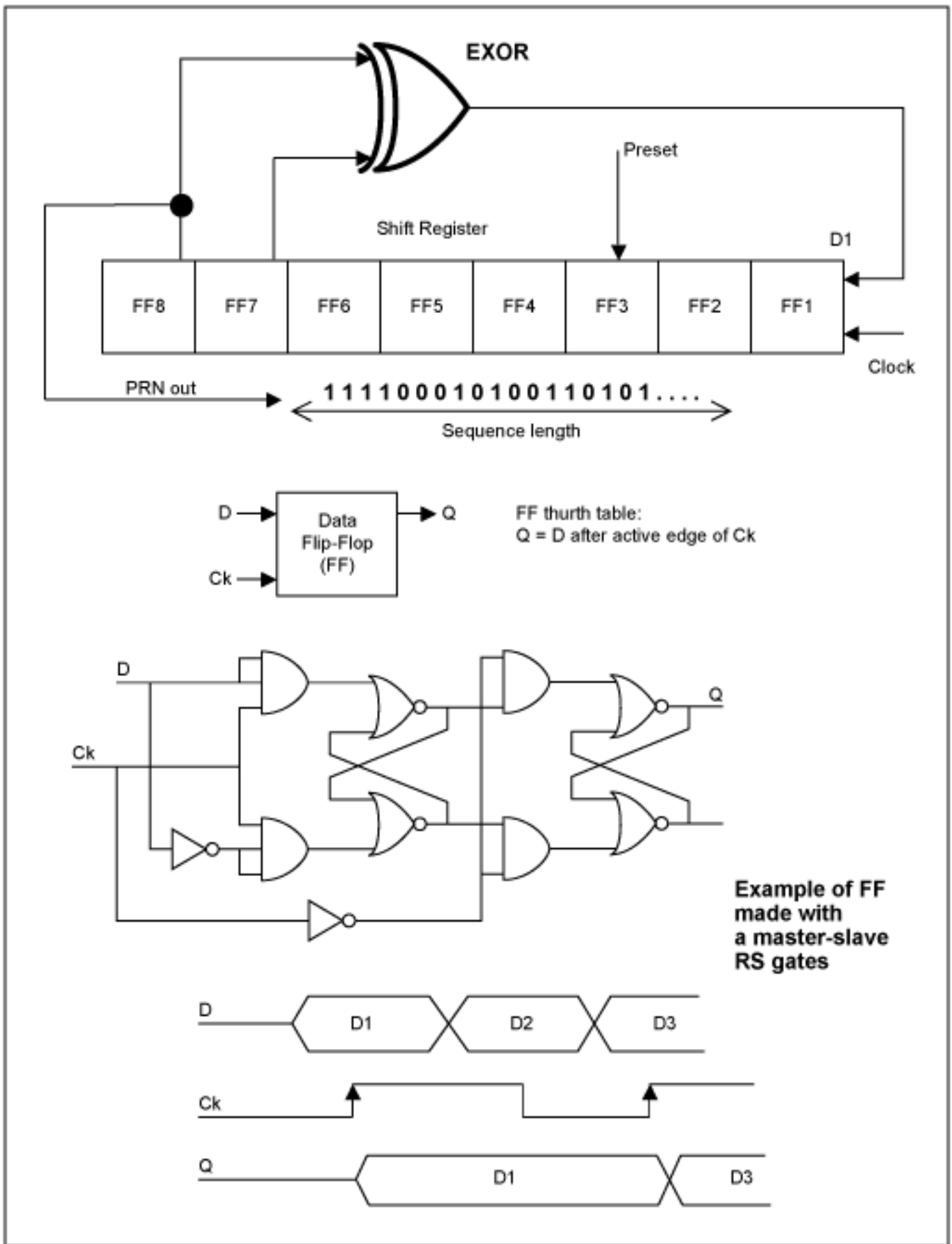

Figure 11.

Many books are available on the generation of PRNs and their characteristics, but that development is outside the scope of this basic tutorial. We simply note that the construction or selection of proper sequences (or sets of

sequences) is not trivial. To guarantee efficient SS communications, the PRN sequences must respect certain rules, such as length, auto-correlation, cross-correlation, orthogonality, and bits balancing. The more popular PRN sequences have names: Barker, M-Sequence, Gold, Hadamard-Walsh, etc. Keep in mind that a more complex sequence set provides a more robust SS link. But, the price to pay is a more complex electronics (both in speed and behavior), mainly for the SS despreading operations. Purely digital SS despreading chips can contain more than several million equivalent 2-input NAND gates, switching at several tens of megahertz.

Different Modulation Spreading Techniques for Spread Spectrum

Different SS techniques are distinguished according to the point in the system at which a pseudo-random code (PRN) is inserted in the communication channel. This is very basically illustrated in the here below RF front end schematic :

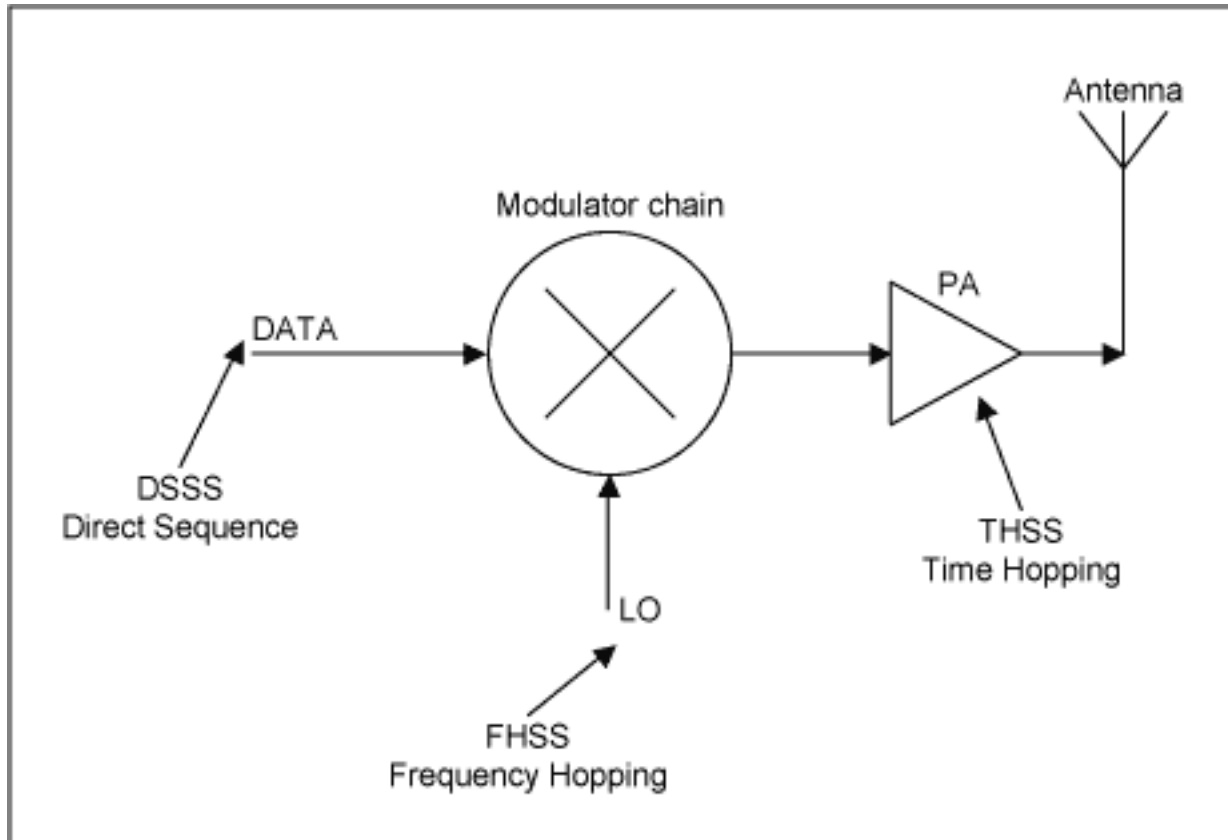

Figure 12.

If the PRN is inserted at the data level, we have the direct sequence form of spread spectrum (DSSS). (In practice, the pseudo-random sequence is mixed or multiplied with the information signal, giving an impression that the original data flow was "hashed" by the PRN.) If the PRN acts at the carrier-frequency level, we have the frequency hopping form of spread spectrum (FHSS). Applied at the LO stage, FHSS PRN codes force the carrier to change or hop according to the pseudo-random sequence. If the PRN acts as an on/off gate to the transmitted signal, we have a time hopping spread spectrum technique (THSS). There is also the chirp technique, which linearly sweeps the carrier frequency in time. One can mix all the above techniques to form a hybrid SS technique, such as DSSS + FHSS. DSSS and FHSS are the two techniques most in use today.

Direct Sequence Spread Spectrum (DSSS)

In this technique, the PRN is applied directly to data entering the carrier modulator. The modulator therefore sees a much larger bit rate, which corresponds to the chip rate of the PRN sequence. The result of modulating an RF carrier with such a code sequence is to produce a direct-sequence-modulated spread spectrum with $(\sin x)/x^2$ frequency spectrum, centered at the carrier frequency.

The main lobe of this spectrum (null to null) has a bandwidth twice the clock rate of the modulating code, and the sidelobes have null-to-null bandwidths equal to the code's clock rate. Illustrated below is the most common type of direct-sequence-modulated spread spectrum signal. Direct-sequence spectra vary somewhat in spectral shape, depending on the actual carrier and data modulation used. Below is a binary phase shift keyed (BPSK) signal, which is the most common modulation type used in direct sequence systems.

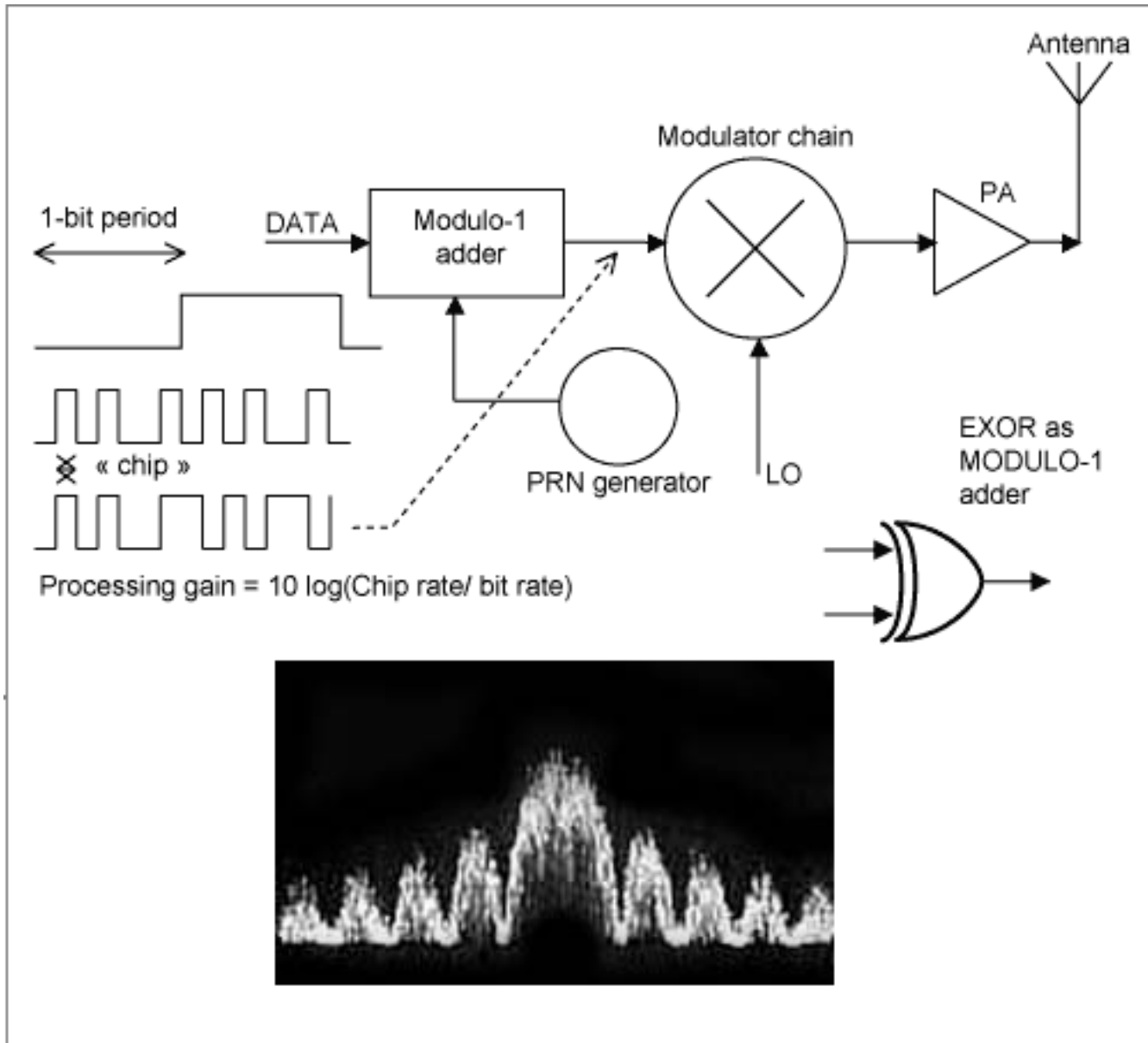

Figure 13. Spectrum-analyzer photo of a direct-sequence (DS) spread-pectrum signal. Note the original signal (non-spread) would only occupy half of the central lobe.

Frequency Hopping Spread Spectrum (FHSS)

This method does exactly what its name implies, it causes the carrier to hop from frequency to frequency over a wide band according to a sequence defined by the PRN. The speed at which the hops are executed depends on the data rate of the original information, but one can distinguish between Fast Frequency Hopping (FFHSS) and Low Frequency Hopping (LFHSS). The latter method (the most common) allows several consecutive data bits to modulate the same frequency. FFHSS, on the other hand, is characterized by several hops within each data bit.

The transmitted spectrum of a frequency hopping signal is quite different from that of a direct sequence system. Instead of a $((\sin x)/x)^2$ -shaped envelope, the frequency hopper's output is flat over the band of frequencies

used (see below). The bandwidth of a frequency-hopping signal is simply N times the number of frequency slots available, where N is the bandwidth of each hop channel.

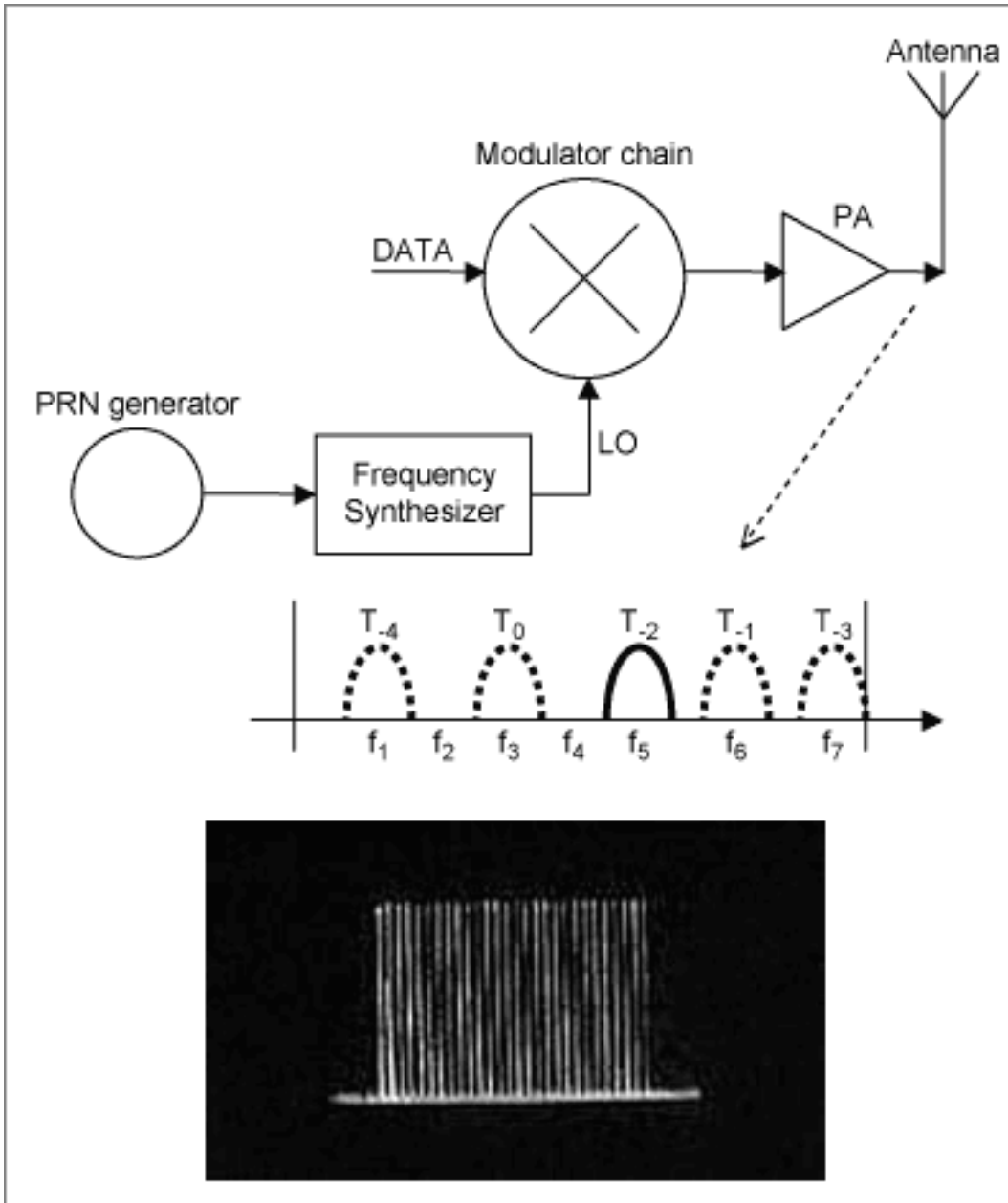

Figure 14. Spectrum-analyzer photo of a frequency-hop (FH) spread-spectrum signal

Time Hopping Spread Spectrum (THSS)

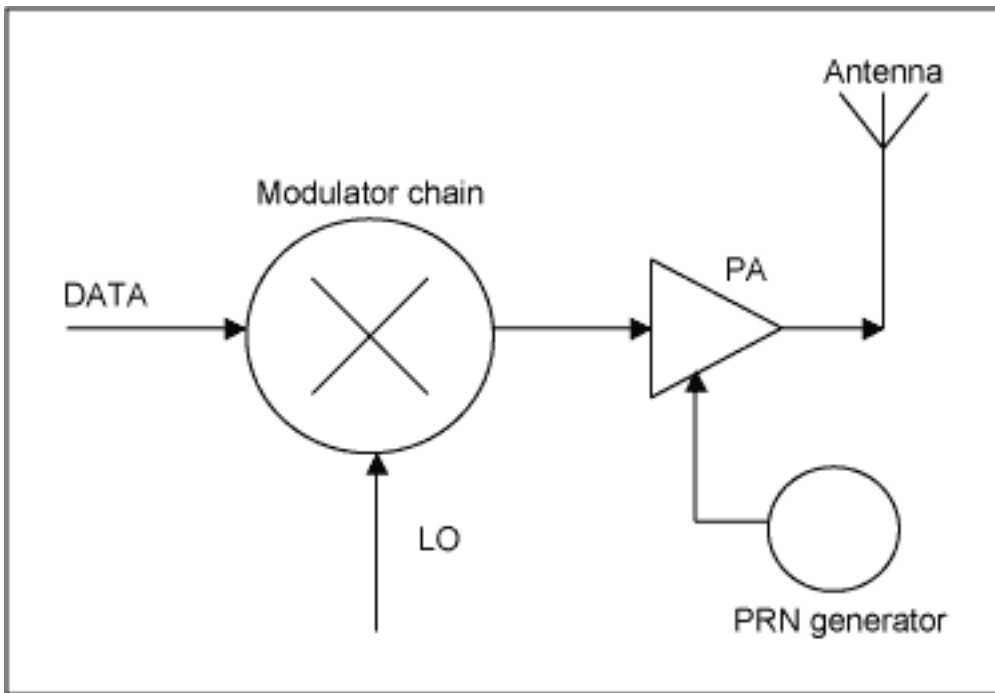

Figure 15.

Here, in a method not well developed today, the on and off sequences applied to the PA are dictated according to the PRN sequence.

Implementations and Conclusions

A complete SS communication link requires various advanced and up-to-date technologies and disciplines: RF antenna, powerful and efficient PA, low-noise, highly linear LNA, compact transceivers, high-resolution ADCs and DACs, rapid low-power digital signal processing (DSP), etc. Though designers and manufacturers compete, they are also joining in their effort to implement SS systems.

The most difficult area is the receiver path, especially at the despreading level for DSSS, because the receiver must be able to recognize the message and synchronize with it in real time. The operation of code recognition is also called correlation. Because correlation is performed at the digital-format level, the tasks are mainly complex arithmetic calculations including fast, highly parallel binary additions and multiplications. The most difficult aspect of today's receiver design is synchronization. More time, effort, research, and money has gone toward developing and improving synchronization techniques than toward any other aspect of SS communications.

Several methods can solve the synchronization problem, and many of them require a large number of discrete components to implement. Perhaps the biggest breakthroughs have occurred in DSP and in application specific integrated circuits (ASICs). DSP provides high-speed mathematical functions that analyze, synchronize, and decorrelate an SS signal after slicing it in many small parts. ASIC chips drive down costs via VLSI technology, and by the creation of generic building blocks suitable for any type of application.

Application Note 1890: <http://www.maxim-ic.com/an1890>

More Information

For technical questions and support: <http://www.maxim-ic.com/support>

For samples: <http://www.maxim-ic.com/samples>

Other questions and comments: <http://www.maxim-ic.com/contact>

AN1890, AN 1890, APP1890, Appnote1890, Appnote 1890

