

**Corrections to first printing of:
Introducing the Theory of Computation
Wayne Goddard**

1. page vi line 9: “each of” should be “four of”
2. page 28 example 3.9: third line “A” should be “B”
3. pages 37 and 38: from the Theorem on page 37 to the end of the section, “FA” should be “DFA”
4. page 57 example 6.7: third line should be “ $VP \rightarrow V NP$ ”
5. page 59 example 6.10: penultimate line should be “ $T \rightarrow TV \mid \varepsilon$ ”
6. page 77 last line: should be “finite sets of $Q \times (\Gamma \cup \{\Delta\})^*$ ”
7. page 78: in 10th line from bottom, “ $[q_0, \Delta, h_a]$ ” should be “ $\boxed{q_0 \Delta h_a}$ ”
8. page 97 line before Example 10.4: “nonterminal” should be “terminal”
9. page 105: 1st two lines of grammar should have been:
 $S \rightarrow RL$
 $L \rightarrow LF \mid v$

In the table, the entries in row 2 column 2, row 4 column 4, and row 6 column 6, should be “ L, I ”

10. page 121: the TM is wrong. This is the correct one:

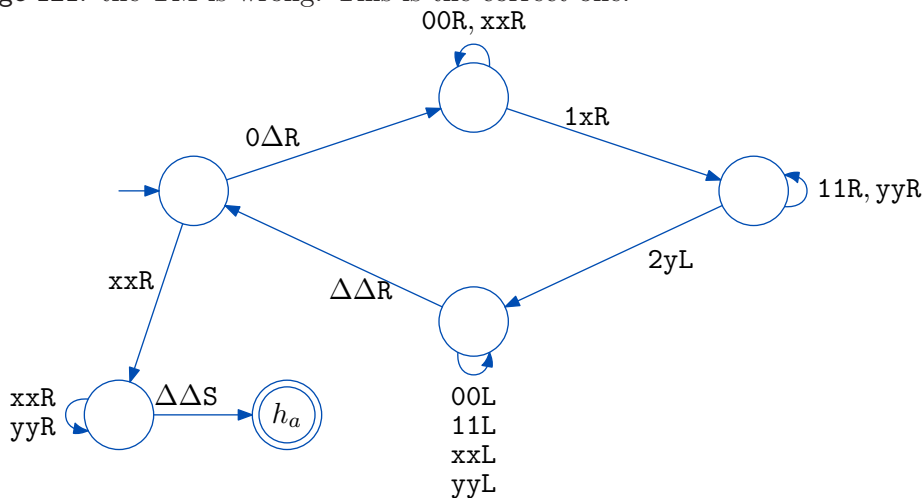

11. page 144: proof at top of page: in three places “ $\langle M' \rangle$ ” should be just “ M' ”:

By contradiction. Suppose there exists a TM that accepts this language; call it M' . Does the machine M' accept $\langle M' \rangle$? Well, $\langle M' \rangle$ is in S_{tm} if and only if M' does not accept $\langle M' \rangle$. That is, M' accepts $\langle M' \rangle$ if and only if M' does not accept $\langle M' \rangle$. A contradiction. Because the logic is correct, the problem must be that the supposition is false: M' does not exist.

12. page 163: penultimate line of Proof: “old1reason” should be “old reason”
13. page 166: “For you to do” Exercise solutions 1: “*sub*” should be “*monus*” in each case
14. page 172: It is not known that a 2-tape TM can simulate any multitape TM while only increasing the running time by a constant factor. The known increase is logarithmic in the size of the input.
15. page 185: 8th line from bottom, “ $\mathcal{NL} \subseteq P$ ” should be “ $\mathcal{NL} \subseteq \mathcal{P}$ ”
16. page 195 Exercise 19.13c: in first line it should be “the problem from (b) is \mathcal{NP} -complete”