

Consensus Functions

on Graphs and Posets

Mini Conference, Clemson

22 October 2009

F.R. McMorris

B.A. Novick

O. Ortega

R.C. Powers

F.S. Roberts

R.V. Vohra

▫ Problem: achieve consensus among a group of 'agents' or 'clients' by a rational process.

▫ Model: a consensus function:

input: information on the clients

output: the outcomes of the process

rationality: guaranteed by rules

(consensus axioms) imposed on

the function.

[Consensus function]

- V finite set with power set 2^V ,
- (V, σ) discrete structure,
- $\pi = v_1, v_2, \dots, v_k$ with $v_1, v_2, \dots, v_k \in V$ is a profile on (V, σ) of length $|\pi| = k$,
- V^* set of all profiles on (V, σ) .
- $L : V^* \rightarrow 2^V - \emptyset$ consensus function on (V, σ) satisfying consensus axioms in terms of σ .

[Consensus axioms]

Consensus axioms:

(A) Anonymity: $L(\pi) = L(\pi_s)$

for every permutation π_s of π ,

(F) Faithfulness: $L(v) = \{v\}$,

(U) Unanimity: $L(v, v, \dots, v) = \{v\}$,

(C) Consistency: $L(\pi) \cap L(\rho) \neq \emptyset \Rightarrow$
 $\Rightarrow L(\pi, \rho) = L(\pi) \cap L(\rho)$,

(B) Betweenness: $L(u, v) = I_\sigma(u, v)$

if structure σ admits an

interval function I_σ . 4

[Median function]

- $G = (V, E)$ connected graph,
- $\pi = v_1, v_2, \dots, v_k$ profile on G ,
- $D(x, \pi) = \sum_i d(x, v_i)$,
- $M(\pi) = \{ x \mid x \text{ minimizes } D(x, \pi) \}$,
- $M: V^* \rightarrow 2^V - \emptyset$ median function on G .
- Lemma. M satisfies (A), (B), and (C).

[Example]

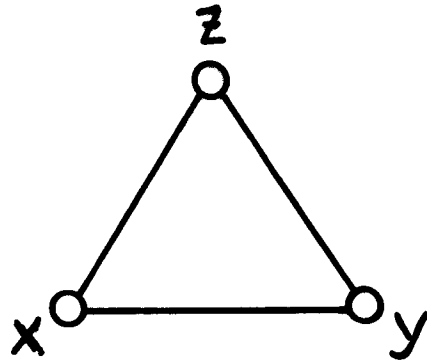

π

$M(\pi)$

x, y, z

{x, y, z}

x, x, y, z

{x}

x, x, y, y, z

{x, y}

[mis(c)]

□ M median function on connected graph.

Then M is consistent.

Proof. Take profiles π and ρ .

Let $x \in M(\pi\rho)$

$y \in M(\pi) \cap M(\rho)$.

Then

$$D(x, \pi\rho) = D(x, \pi) + D(x, \rho)$$

$$\geq D(y, \pi) + D(y, \rho) = D(y, \pi\rho)$$

$$\geq D(x, \pi\rho).$$

□ □ □

[Problems]

► Problem. Characterize the consensus functions L on graphs that satisfy (A), (B), and (C).

► Problem. Characterize the graphs on which M is the unique consensus function satisfying (A), (B), and (C),

i.e. L satisfies (A), (B), (C) $\Leftrightarrow L = M$.

[Intervals]

□ $G=(V,E)$ connected graph

$$I(u,v) = \{ x \mid x \text{ on shortest } u,v\text{-path} \}$$

interval between u and v .

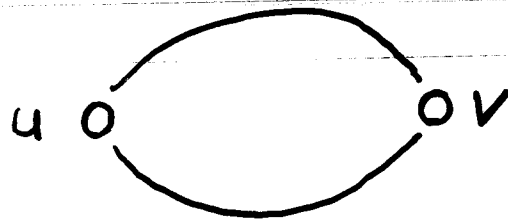

$$I(u,v,w) = I(u,v) \cap I(v,w) \cap I(w,u)$$

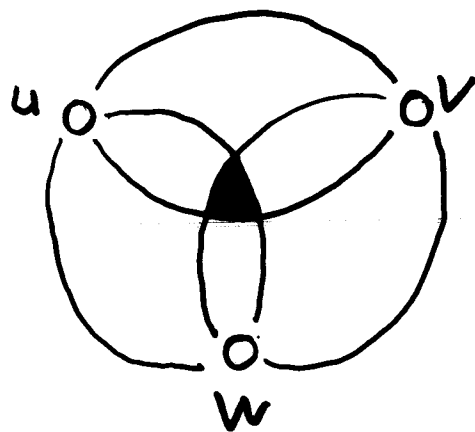

[Two examples]

i)

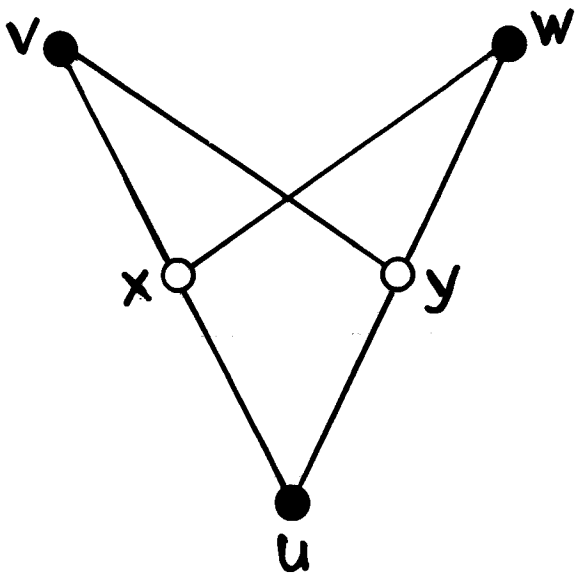

$$I(u,v) = \{u, x, y, v\},$$

$$I(u,v,w) = \{x, y\} \neq \emptyset,$$

$$M(u,v,w) = \{x, y\} = I(u,v,w),$$

$$M(G) = \{x, y\}.$$

ii)

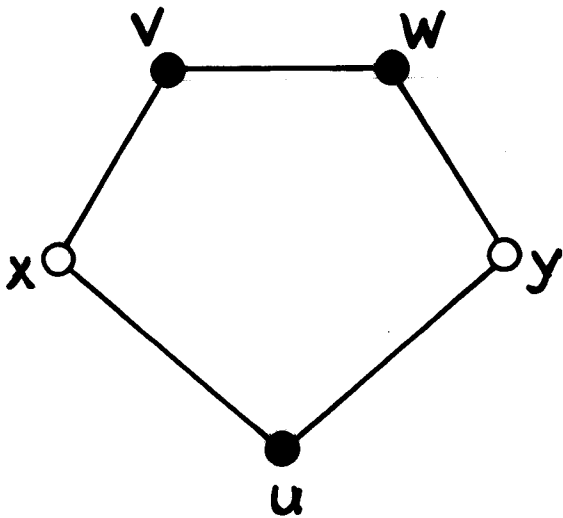

$$I(u,v) = \{u, x, v\},$$

$$I(u,v,w) = \emptyset,$$

$$M(u,v,w) = \{v, w\},$$

$$M(G) = V.$$

[Short profiles]

• Assume L satisfies (A), (B), (C):

• $|\pi| = 1 : L(v) = \{v\} = M(v) \quad (B), (C)$

• $|\pi| = 2 : L(u, v) = I(u, v) = M(u, v) \quad (B)$

• $|\pi| = 3 : L(u, v, w) = ?$

if $I(u, v, w) \neq \emptyset$, then

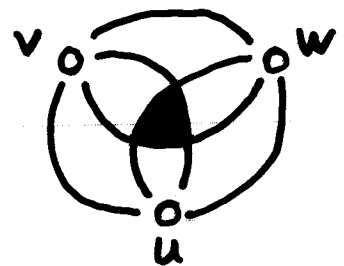

$$\emptyset \neq M(u, v, w) = I(u, v) \cap I(v, w) \cap I(w, u)$$

$$\stackrel{(B)}{=} L(u, v) \cap L(v, w) \cap L(w, u)$$

$$\stackrel{(C)}{=} L(u, v, v, w, w, u)$$

$$\stackrel{(A)}{=} L(u, v, w, u, v, w) \stackrel{(C)}{=} L(u, v, w)$$

[Definition]

□ $G = (V, E)$ graph,

$$I(u, v) = \{ x \mid x \text{ on shortest } u, v\text{-path} \},$$

$$I(u, v, w) = I(u, v) \cap I(v, w) \cap I(w, u).$$

□ G is a median graph if

$$|I(u, v, w)| = 1 \quad \forall u, v, w \in V$$

x median of u, v, w .

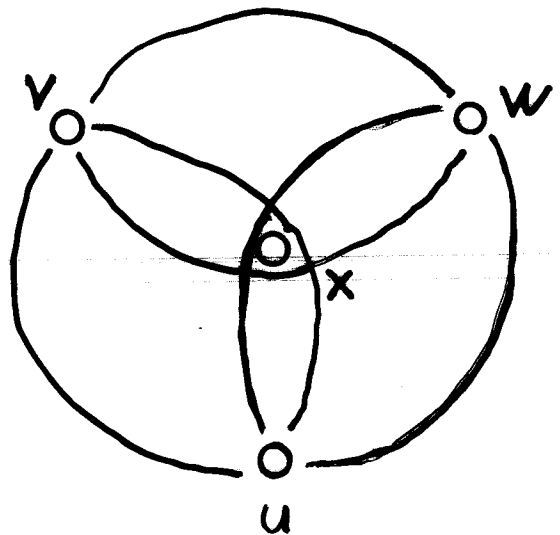

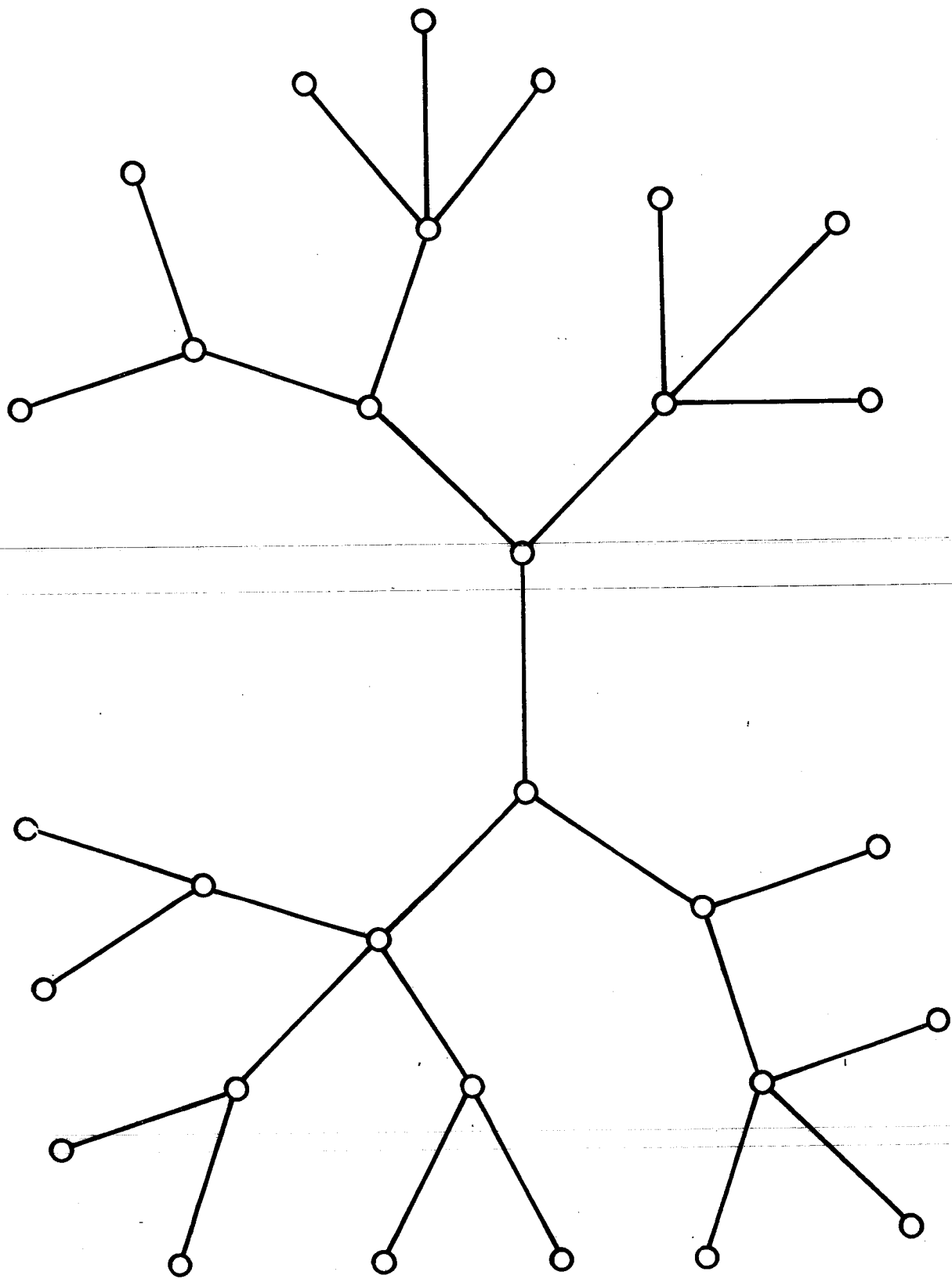

[Q₃ and Q₄]

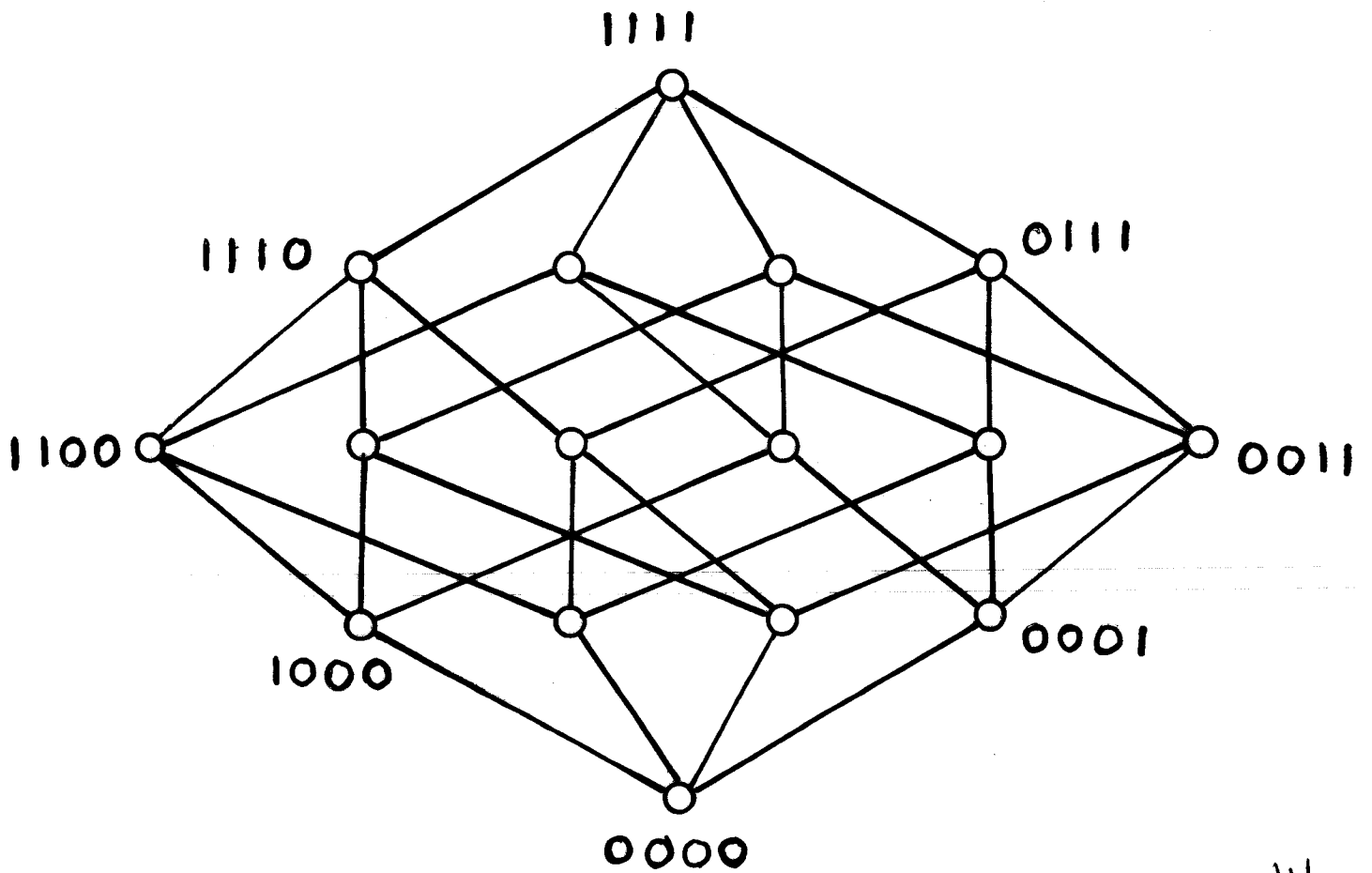
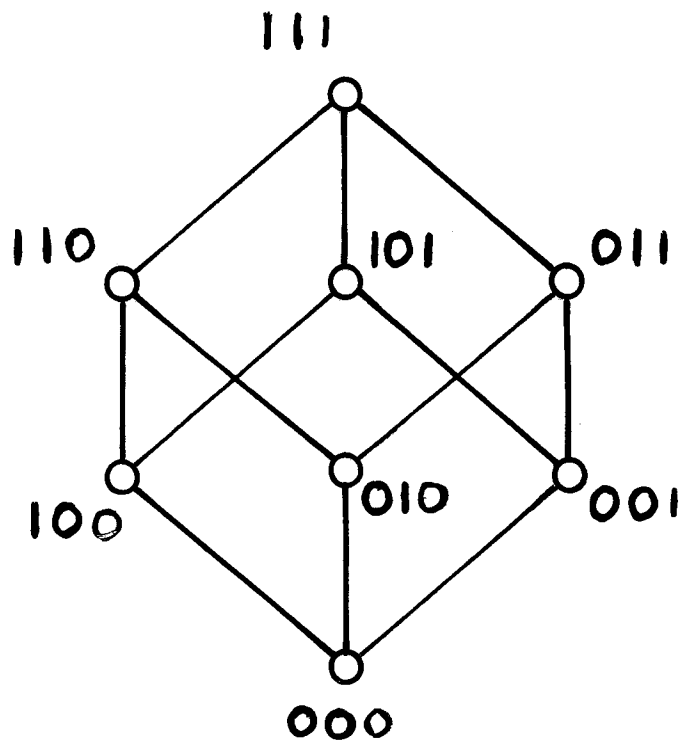

[Expansion Theorem]

▣ Theorem. G median graph

iff G can be obtained from K_1
by convex expansions.

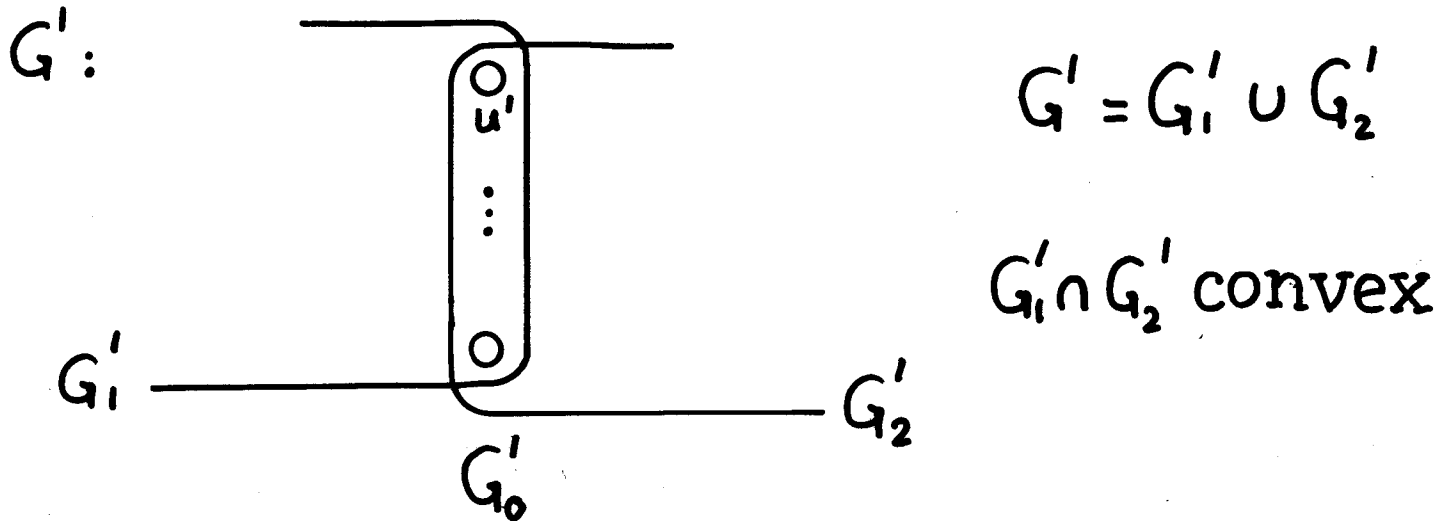

expansion ↙ ↘ contraction

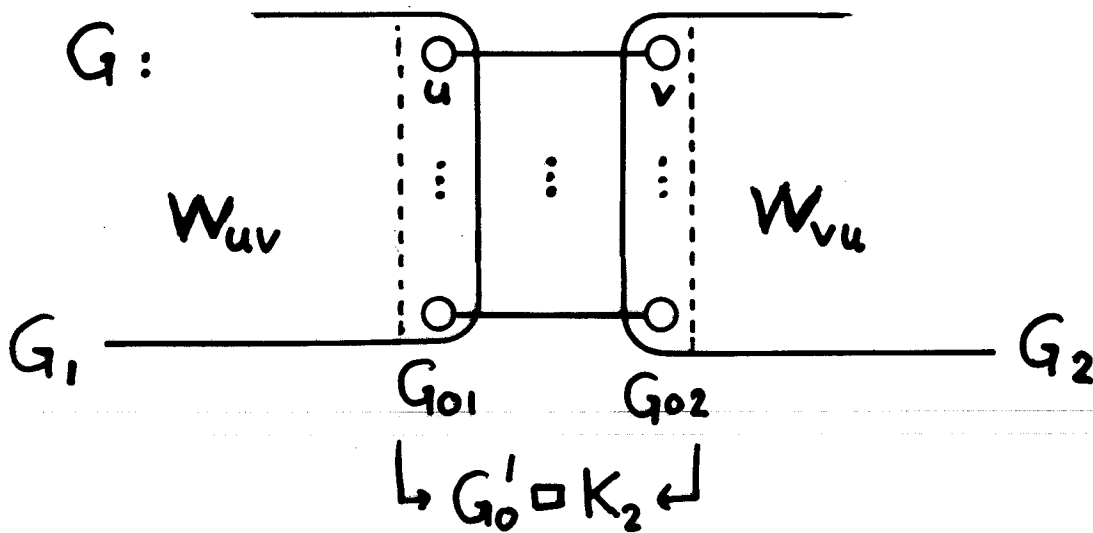

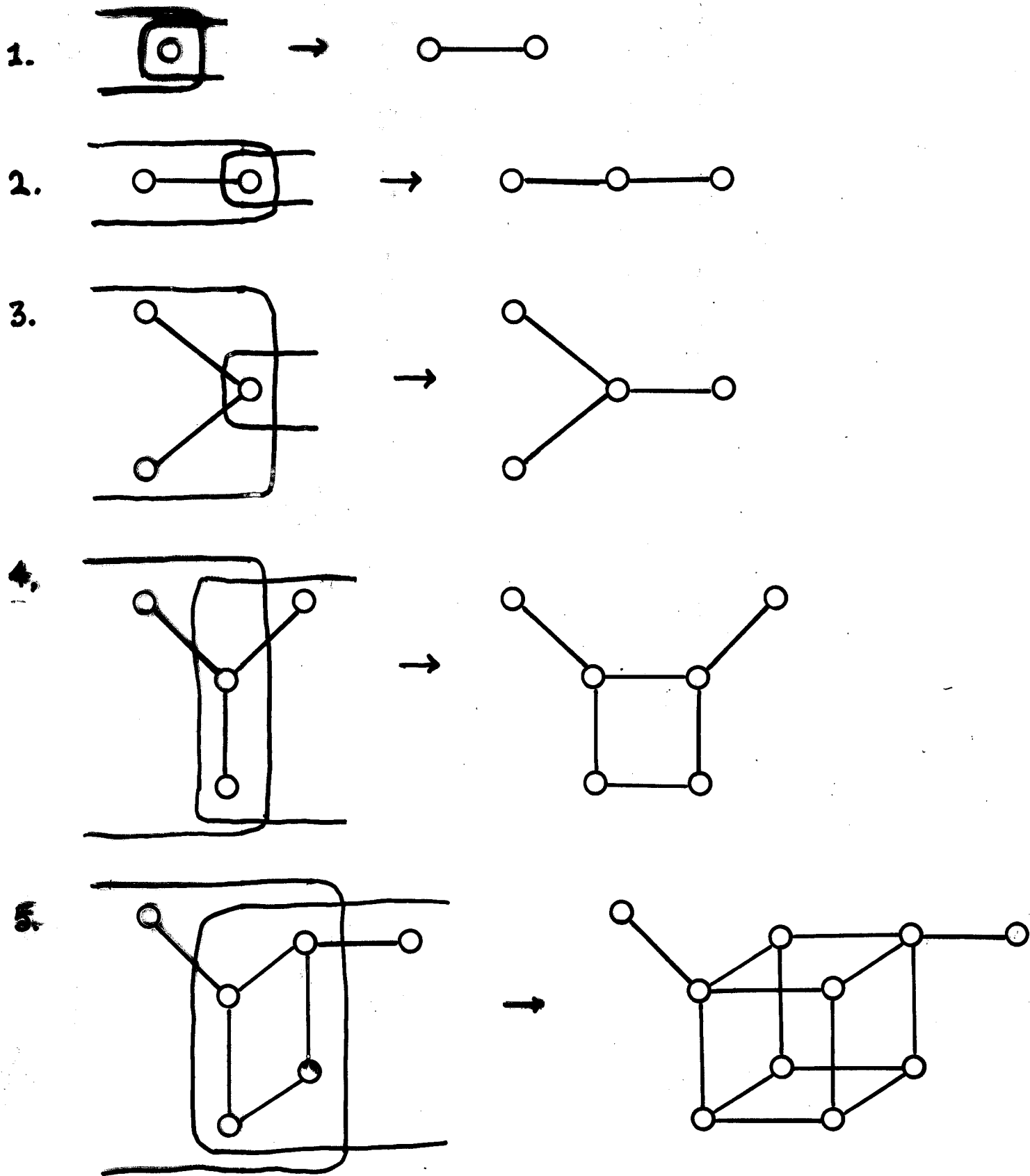

[Split]

- G median graph,
- u_1, u_2 edge of G ,
- G_1 subgraph of vertices
closer to u_1 than to u_2 ,
- G_2 subgraph of vertices
closer to u_2 than to u_1 :

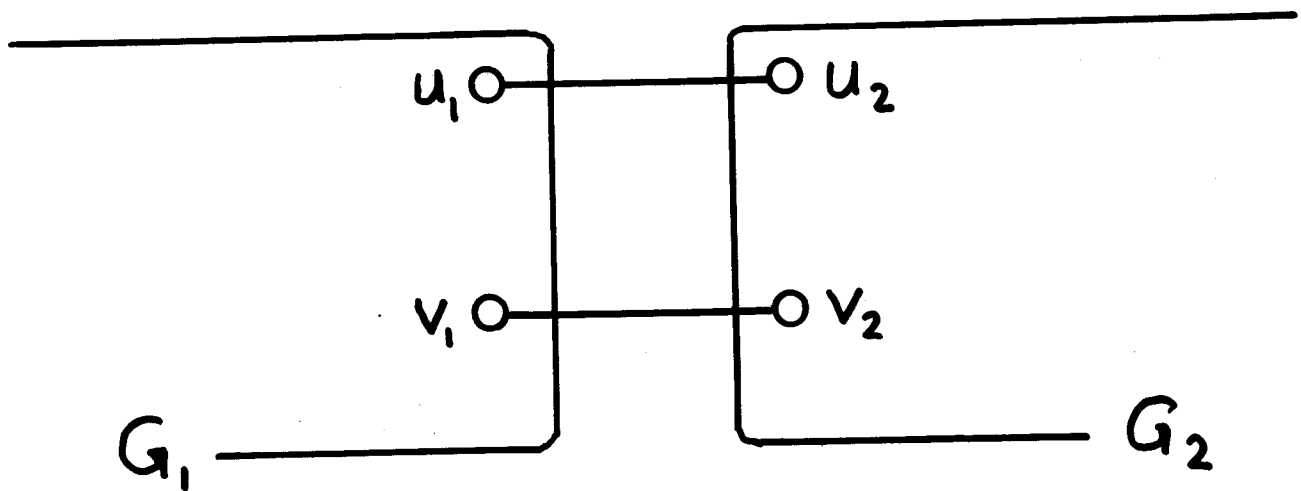

- G_1, G_2 split of u_1, u_2

!! any edge v_1, v_2 with $v_i \in G_i$ defines
the same split G_1, G_2 !!

$$|\pi_1| > |\pi_2|$$

□ Split :

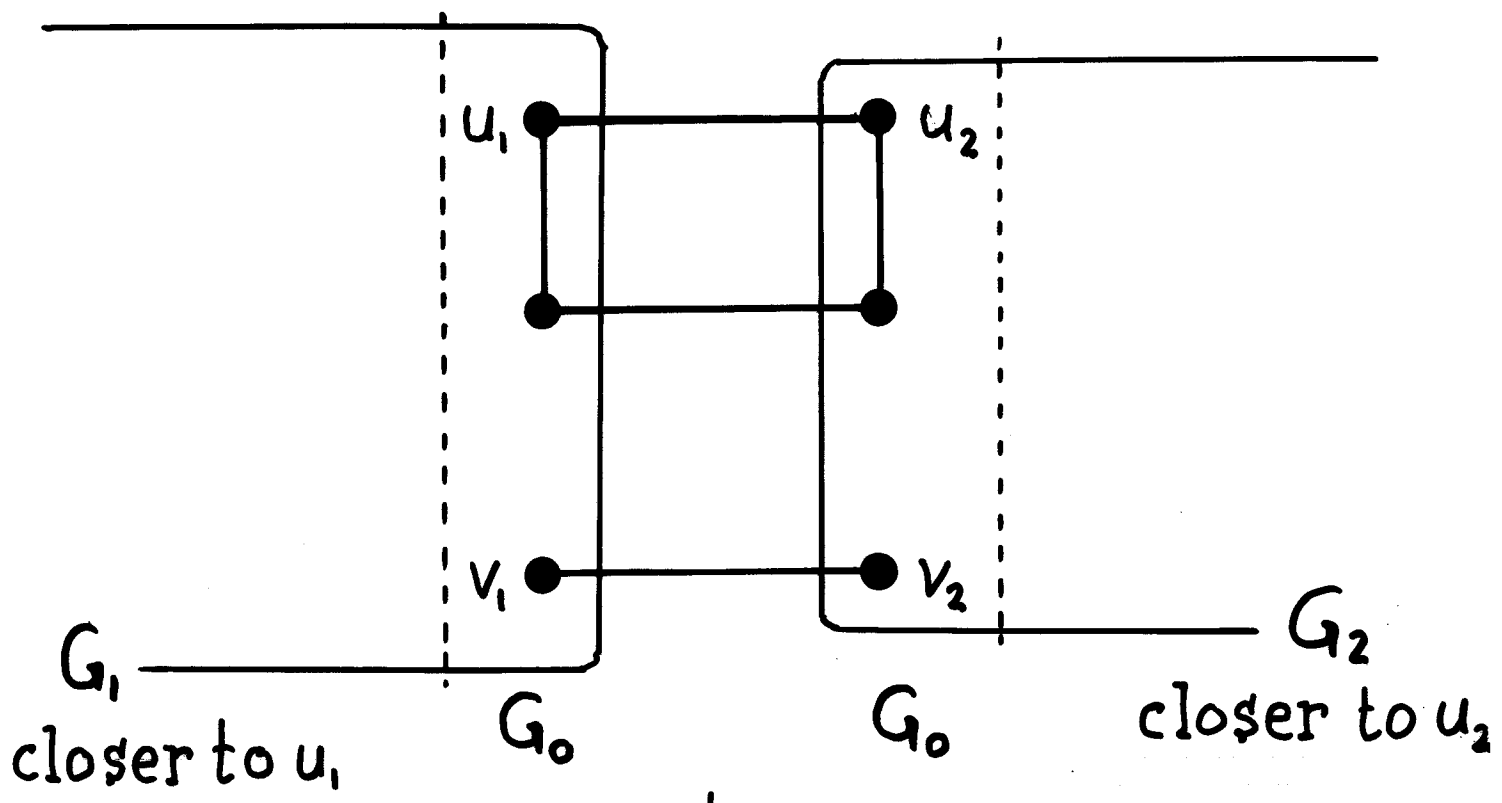

contraction
↓

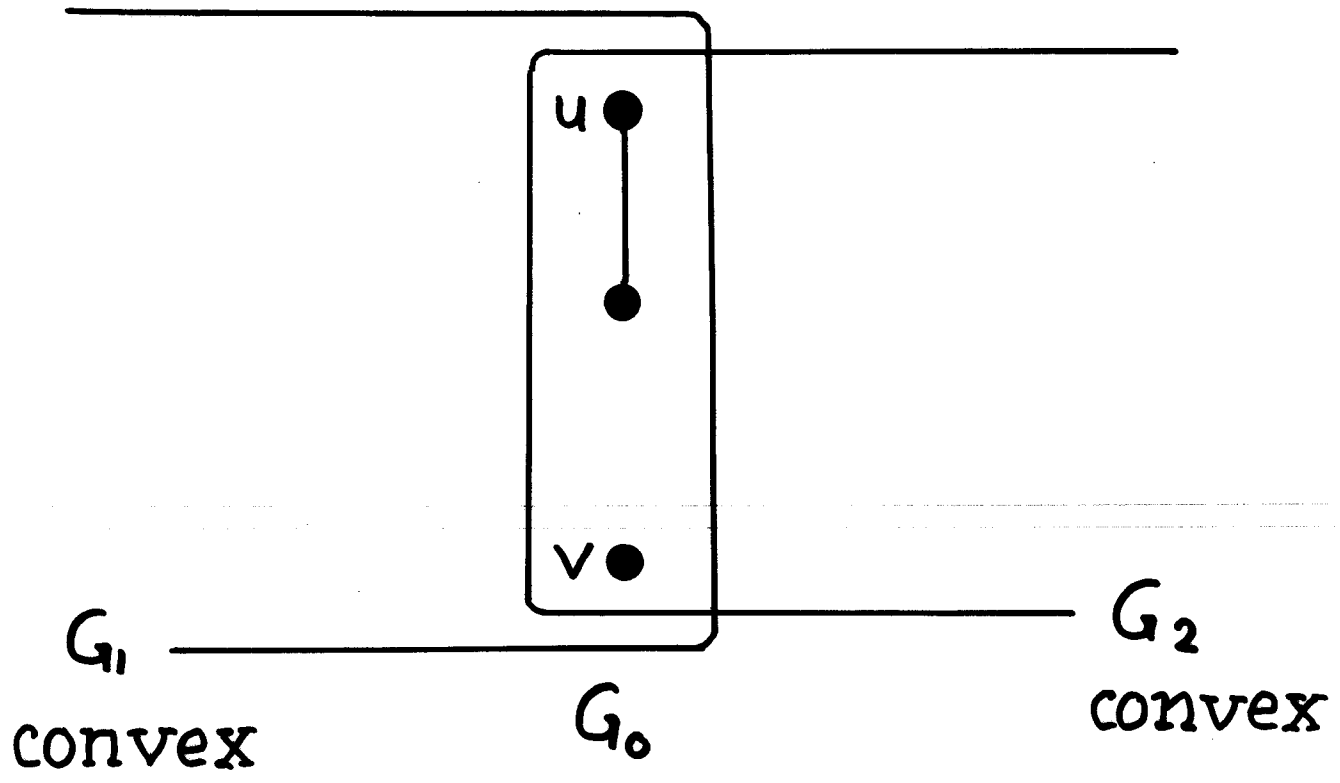

[Majority Theorem]

- G median graph, G_1, G_2 split,
- π profile on G ,
 - π_i subprofile of π on G_i , for $i=1,2$.
- Theorem. If $|\pi_1| > |\pi_2|$, then $M(\pi) \subseteq G_1$.
- Corollary. If $|\pi|$ is odd, then $|M(\pi)| = 1$.

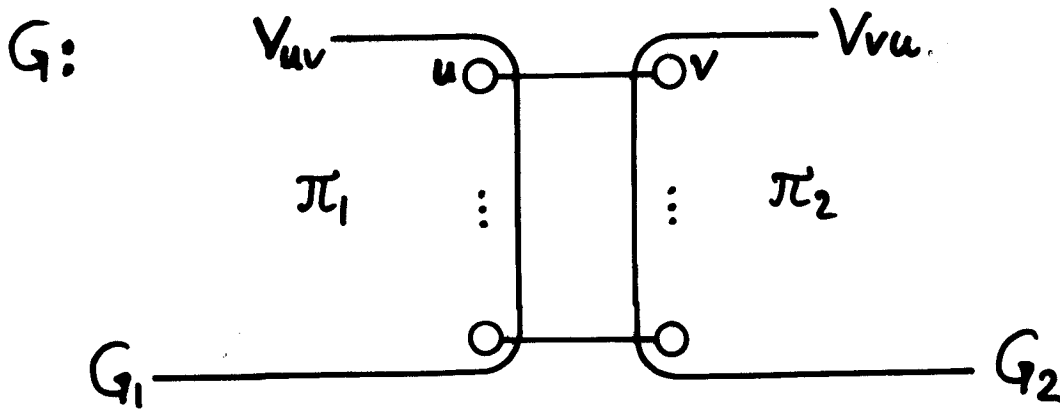
split

$$|\pi_1| > |\pi_2| \Rightarrow M(\pi) \subseteq G_1.$$

$$M(\pi) = \bigcap_{\substack{G_1, G_2 \text{ split} \\ |\pi_1| > |\pi_2|}} G_1.$$

$$\pi \text{ odd} : M(\pi) = \bigcap_{i=1}^k M(\pi - x_i).$$

$$\pi \text{ even} : M(\pi) = \text{Con} \left(\bigcup_{i=1}^k M(\pi - x_i) \right).$$

[Cube-free median]

, Theorem. G cube-free median graph.

If $|\pi| = 2k$, then there exists a permutation

$\pi = y_1, y_2, \dots, y_{2k-1}, y_{2k}$ of π such that

$$M(\pi) = \bigcap_{i=1}^k I(y_{2i-1}, y_{2i}).$$

, Example:

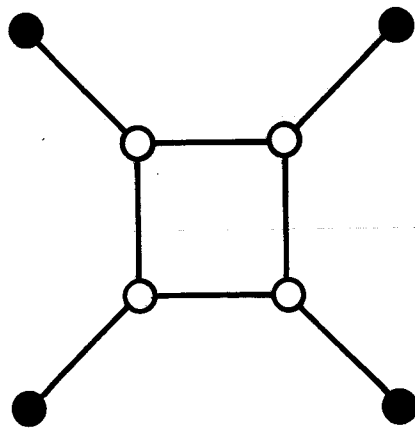

, Corollary. G cube-free median.

If $L : V^* \rightarrow 2^V - \emptyset$, then

L satisfies (A), (B), (C) $\Leftrightarrow L = M$.

[Proof]

Proof. By induction on $|\pi|$.

$$(i) \quad L(x, y) \stackrel{(B)}{=} I(x, y) = M(x, y).$$

$$(ii) \quad \emptyset \neq L(x) = L(x) \cap L(x) \stackrel{(C)}{=} L(x, x) = \\ \stackrel{(i)}{=} M(x, x) = M(x).$$

(iii) $|\pi| \geq 3$:

$$a) \quad \pi \text{ odd: } M(\pi) = \bigcap_i M(\pi - x_i) \stackrel{IH}{=} \bigcap_i L(\pi - x_i) \stackrel{(C)}{=} \\ \stackrel{(C)}{=} L(\pi - x_1, \pi - x_2, \dots, \pi - x_k) \stackrel{(A)}{=} L(\pi, \pi, \dots, \pi) \stackrel{(C)}{=} L(\pi).$$

$\underbrace{\hspace{10em}}_{L_{k-1} \pi}$

$$b) \quad \pi \text{ even: } M(\pi) = \bigcap_i I(y_{2i-1}, y_{2i}) \stackrel{(B)}{=} \\ \stackrel{(B)}{=} \bigcap_i L(y_{2i-1}, y_{2i}) \stackrel{(C)}{=} L(y_1, y_2, \dots, y_{2k}) \stackrel{(A)}{=} L(\pi).$$

□□□

Example:

$$\pi = w, x, y, z$$

$$M(\pi) = V$$

$[(K), (\frac{1}{2}c)]$

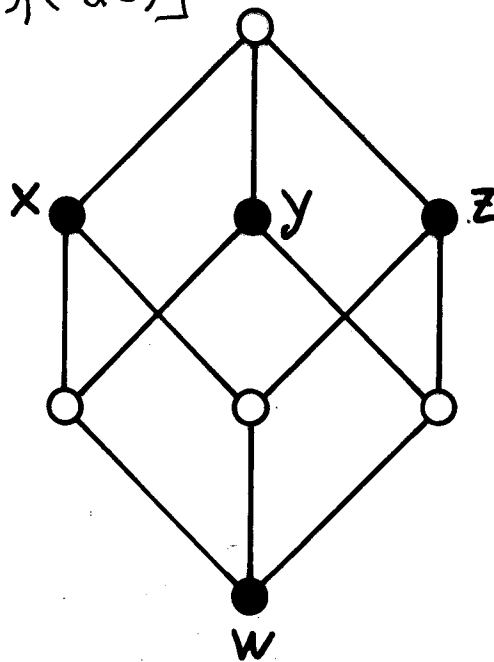

$L(\pi) = \{w, x, y, z\}$ etc., still (A), (B), (C).

On all median graphs: we need an extra axiom:

$$(K) \quad \bigcap_i L(\pi - x_i) = \emptyset \Rightarrow L(\pi) = \text{Con}(\bigcup_i L(\pi - x_i))$$

r

$(\frac{1}{2}c)$ for $vw \in E$ with $|\pi_{vw}| = |\pi_{wv}|$:

$$v \in L(\pi) \Leftrightarrow w \in L(\pi).$$

[open problems]

- Open Problems:
 - ? Characterize all the graphs on which M is uniquely determined by (A),(B),(C).
 - ? Characterize M on other classes (what extra axioms?).
 - ? Characterize other consensus functions.

[Postcard]

∴ I collect postcards sent to me
by mathematicians.

😊 I would be very happy to add
yours to my collection!

Thank You!